



Foodservice Equipment

Job _____ Item# _____

Free-Standing Hot Food Servers 3A81DT09 and 3A81DT72



3A81DT09

Standard Features:

- 20 bearings per drawer
- Positive-action spring-loaded drawer latch
- Rugged third-member drawer rail
- Individual drawer moist/crisp control
- Single thermostat with "safety zone" green
- Fully insulated on all six sides

Additional features of free-standing models:

- Models include 4" NSF-listed legs
- All models include factory-installed cord and plug

Controls:

Temperature is regulated by hydraulic thermostat adjustable from 100°F to 200°F, with "OFF" position. Thermostat control is mounted on front below the drawer and is equipped with adjacent signal light. Thermostat knob is protected by a knob guard.

The moisture control adjustment knob is located at the center front above the drawer. A thermometer accurately reflects the temperature at the coolest point inside the server. This safety feature helps ensure that food products are being held at a temperature above the bacterial growth level, and at temperatures below those that may over cook or dry out food product.

Controls:

Unit is designed to hold precooked foods at serving temperature, ideal for baked potatoes, vegetables, ribs, buns and rolls. Each drawer holds one 12" x 20" pan, 5-1/4" deep.

Warranty:

Warranty includes one year parts and labor, on-site service. (USA only) Call factory for warranty authorization.

Application:

Hot food servers are designed to hold cooked foods at a safe, thermometer verified serving temperature and proper moisture content. Hot food can be placed into the drawer either directly or in separate open pans or containers. Holding temperature and moisture content can be set for the type of food being held.

General Information:

Freestanding, drawer-type hot food server. The drawer is furnished with a removable, deep drawn stainless steel pan. This model includes a set of 4" NSF approved adjustable legs.

Heating:

Heating is accomplished with performed tubular heating elements.

Construction:

The frame is of welded and reinforced sheet steel. The exterior cabinet and drawer fronts are of stainless steel with an aluminized steel inner lining. Drawers are equipped with a handle operated latching mechanism and positive stop. Drawers glide on third member suspension system rails. Third members have five (5) roller bearings (load support) and five (5) guide bearings (smooth operation) each (i.e. twenty (20) bearings per drawer).

Insulation:

Fully insulated on all six sides, including drawer fronts.

Electrical:

Provide with a factory installed 3 foot cord and plug: NEMA 5-15 plug for 120V, NEMA 6-15 plug for 208/240V. Single phase only. See electrical data chart on reverse side.



ToasterMaster® 10 Sunnen Dr. St. Louis, MO 63143 • www.toastmastercorp.com

Toll Free: 1-800-264-7827 • Telephone: 1-314-781-2777 • Toll Free Fax: 1-800-264-6666 • Fax: 314-781-3636

Free-Standing Hot Food Servers

3A81DT09 and 3A81DT72

Model Number	3A81DT09	3A81DT72
Drawers	1	1
Thermostats	1	1
Supply	120V	208V / 240V
Current Draw	3.91 Amps	208V - 1.97 A 240V - 1.97 A
Heat Input	.45 KW	208V - .41 KW 240V - .41 KW
Factory Installed 36" cord & plug	NEMA 5-15P	208 V / 240 V NEMA 6-15
Dimensions	29-1/16" W x 11" H x 20-3/8" L	29-1/16" W x 11" H x 20-3/8" L
Pan Size	12"x20"x5-1/4"	12"x20"x5-1/4"
Shipping Weight	94 lbs.	94 lbs.

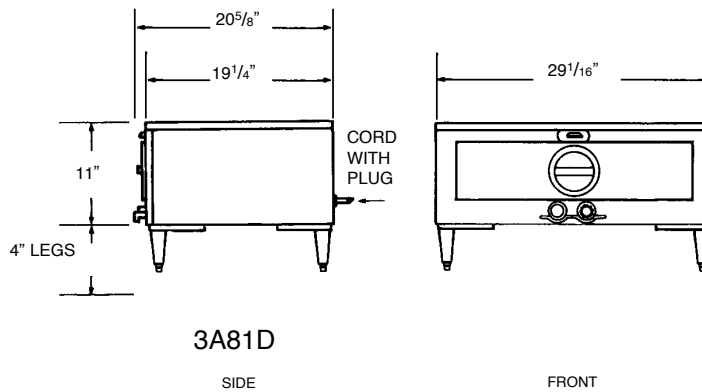

INTENDED FOR COMMERCIAL USE ONLY. NOT FOR HOUSEHOLD USE.

TM123/1060

Toastmaster

Toastmaster, in line with its policy to continually improve its product, reserves the right to change materials or specifications without notice. Such revisions do not entitle the buyer to corresponding changes, improvements, additions, or replacements for previously purchased equipment.

THE MIDDLEBY CORPORATION
THE BRAND BEHIND THE BRANDS

Toastmaster® 10 Sunnen Dr. St. Louis, MO 63143 • www.toastmastercorp.com

Toll Free: 1-800-264-7827 • Telephone: 1-314-781-2777 • Toll Free Fax: 1-800-264-6666 • Fax: 314-781-3636