



Countertop Electric Fryer

Models *TECF142772, TECF143970*



TECF142772



TECF143970

Model Shown: *May ship UPS, except TECF143970*

Application

The Toastmaster Electric Countertop Fryers is the most economical and flexible Electric Countertop Fryer in the food service industry. It offers unsurpassed performance, combining proven control system with Toastmaster quality and durability. They are designed to efficiently fry variety of products by immersion into heated liquefied shortening.

Available in two different sizes, 15 lbs. and 30 lbs. (twin 15 lbs.) shortening capacity.

Heating:

The fryers are equipped with immersion type stainless steel tubular heating elements which swing up and burn clean pyrolytically in the raised position. The elements configuration surrounds the sides, front, back and bottom of the shortening container. A handle is provided for raising and lowering the heating elements.

Controls:

Shortening temperature is controlled by a thermostat from 250°F to 400°F with a positive "OFF" position.

Warranty:

Product warranty includes one year parts and labor. (USA only) Call factory for warranty authorization.

Cleanability:

- Swing up heating element.
- Removable stainless steel tank.

Electrical:

The 1427 has a rated input of 6 KW at 240 volts and 4.5 KW at 208V. TECF 1439 has a rated input of 11.4 KW for 240 Volts and 8.5 KW for 208 Volts. Available in 208/240V AC 1 phase or 480V AC 3 phase.

Standard Features:

- The exterior case is made of stainless steel, welded and reinforced at front, sides and top. The rear is made of aluminized steel.
- The fryers are equipped with immersion type stainless steel tubular heating elements which swing up and burn clean pyrolytically in the raised position.
- The elements configuration surrounds the sides, front, back and bottom of the shortening container. A handle is provided for raising and lowering the heating elements.
- A cold zone is provided beneath heating elements to collect loose food particles.
- The cooking temperature is controlled by an adjustable thermostat from 250°F to 400°F with a positive "OFF" setting. A signal light cycles with the heaters.
- The fryer includes a temperature limiting thermostat which functions if an overheated condition exist. A signal light denotes "overheated" when the temperature limiting thermostat has sensed an overheated condition.
- The temperature limiting thermostat require manual resetting when tripped and reset after pyrolytic cleaning.



Countertop Electric Fryer - Models: **TECF142772, TECF143970**

Countertop Electric Fryer - Models: TECF142772, TECF143970

Countertop Electric Fryer

Models TECF142772, TECF143970

Models shown may ship UPS, except TECF143970

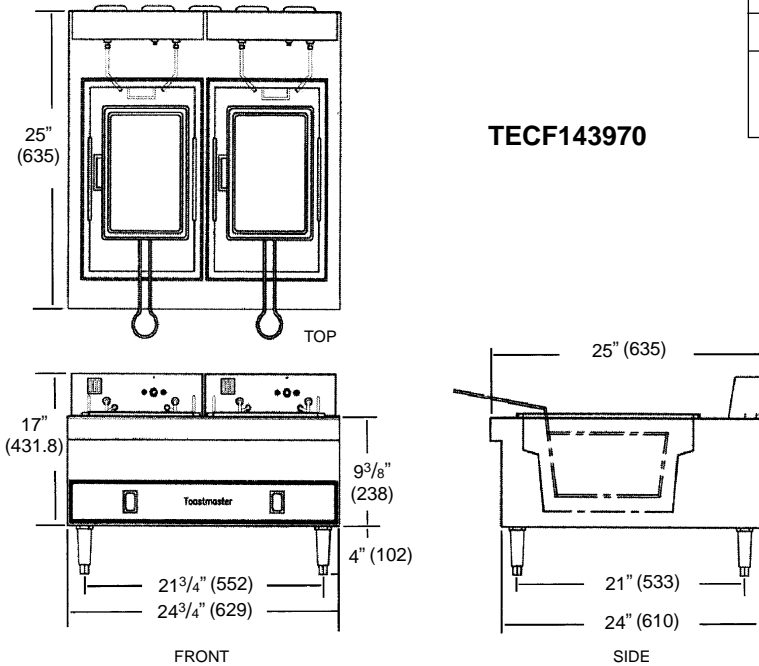
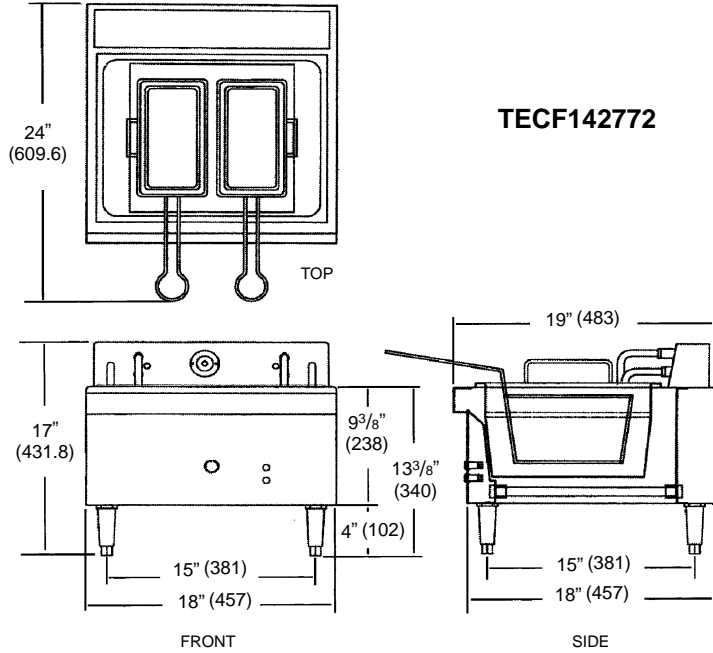

Model Number	TECF143970	TECF142772
Supply	208/240 V	208/240 V
Current Draw (Amps)	208/3 - 47.5 240/3 - 41.2	208/1 - 21.6 240/1 - 25
Total KW	208 V - 8.5 240 V - 8.5	208 V - 4.5 240 V - 6
Capacity	(2) 15 lb tanks	(1) 15 lb tanks
Weight	84 lbs.	50 lbs.
Dimensions	24-3/4" W x 16-7/8" H x 25" L	18" W x 17" H x 19" L

INTENDED FOR COMMERCIAL USE ONLY. NOT FOR HOUSEHOLD USE.



ToasterMaster, in line with its policy to continually improve its product, reserves the right to change materials or specifications without notice. Such revisions do not entitle the buyer to corresponding changes, improvements, additions, or replacements for previously purchased equipment.

