



## XO-1MSS Steam Retherm Oven Tabletop Oven



**SIZE:**

**XO-1MSS** - 37" High, 31-3/8" Wide, 33" Deep  
940 mm High, 797 mm Wide, 838 mm Deep

The **XO-1MSS** Steam Retherming Oven could be just what you need to replace expensive combi ovens.

While maintaining a small footprint, this unit is able to provide you with a large capacity up to 10 bags of product. The availability of the stacking option could double your capacity while utilizing the same amount of floor space.

Toastmaster has made the XO-1MSS easy to clean. Convenient placement of the water reservoir facilitates easy cleaning and minimizes build up of deposits. There are no tools, and no service call required. Simply open the seal-less reservoir cover for de-scaling and cleaning.

The XO-1MSS preheats and recovers quickly while in use, and has proven to be quicker than a traditional steamer. This is the ideal unit for soups, pasta, veggies and more!

**CONSTRUCTION:**

- Welded stainless steel
- Fully insulated
- Control panel accessible through front of unit
- Heating elements accessible inside of cabinet and through side

**CONTROLS:**

- Solid state controls

### XO-1MSS Steam Retherm Oven

**STANDARD FEATURES:**

- Stainless steel construction
- 4" adjustable legs
- Stainless steel door
- Solid state controls
- Silicone rubber gasket on door
- 60 Minute timer
- Magnetic door handle

**OPTIONS:**

- Wire Shelf Racks each (98-0401)
- Stand without Panslides (98-0373)
- Stacking Kit

*Note: Units cannot be stacked when using cart or stand.*

### LABORATORY CERTIFICATION AND APPROVAL



# XO-1MSS Steam Retherm Oven

Toastmaster XO-1MSS Steam Retherm Oven

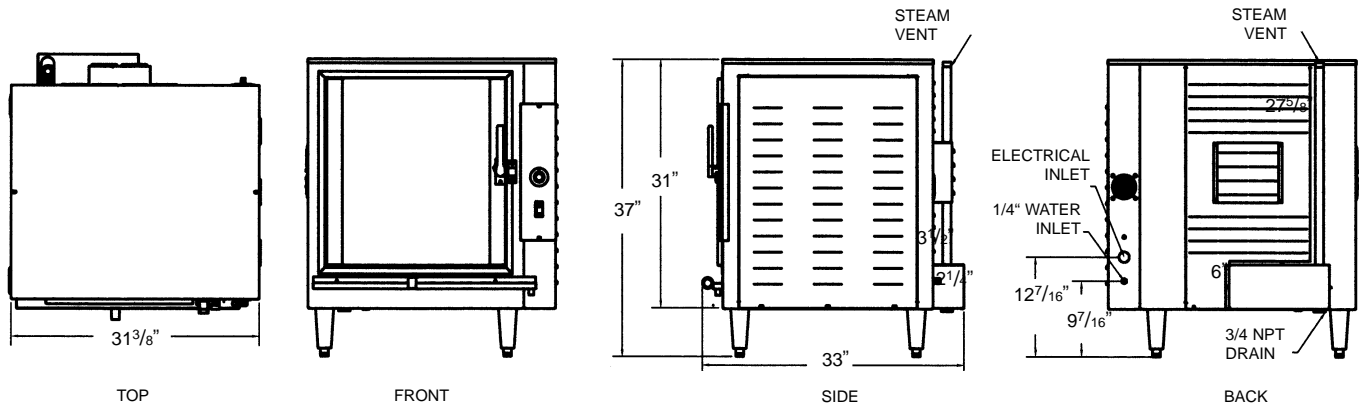

**SPECIFICATIONS:**

**ELECTRICAL:**

- 208 or 240 Volt 3 phase is standard. Please specify at time of order.

**SERVICE CONNECTIONS:**

- Unit is shipped from factory to be hard wired on site. Three phase uses four wire system.

**ELECTRICAL:**

	208/1	208/3	240/1	240/3
Amp Draw	n/a	23	n/a	20

**LISTINGS:**

The XO-1MSS has C-ETL-US & ETL sanitation listings.



**INSTALLATION:**

Allow four inches on each side and back of unit for ventilation of oven.

**CAPACITY:**

	13"x18" Sheet Pans	12"x20"x2-1/2" Food Service Pans
	6	6
Spacing	3-11/16"	3-11/16"

**DIMENSIONS:**

	Height	Width	Depth
Exterior	37"	31-3/8"	33"
Interior	22"	21-1/4"	15"

**DOOR SWING:** Oven - 22-3/4" (578 mm)

**PACKING SIZE:**

32" High, 36" Wide, 36" Deep  
(813 mm High, 914 mm Wide, 914 mm Deep)

**SHIPPING WEIGHT:**

180 Pounds (64 Kg), FOB Menominee, MI 49858

**INTENDED FOR COMMERCIAL USE ONLY. NOT FOR HOUSEHOLD USE.**



Toastmaster, in line with its policy to continually improve its product, reserves the right to change materials or specifications without notice. Such revisions do not entitle the buyer to corresponding changes, improvements, additions, or replacements for previously purchased equipment.

