



# RM-5T Tabletop Convection Oven



**SIZE:**

**RM-5T** - 41-3/4" High, 30" Wide, 36" Deep  
1060 mm High, 762 mm Wide, 915 mm Deep

The **Toaster's RM-5T** tabletop oven features our exclusive moving air system. Heat is distributed evenly throughout the oven cavity by the fan located in the top of the oven which blows the air down the inside walls of the cavity and up and out through the holes at each shelf. This gives your product an even bake, top to bottom, side to side, and front to back and requires less energy per pan. The two speed fan allows baking and cooking all types of products.

The standard RM-5T offers you precise baking and cooking of 5 full size sheet pans with generous 4 inch spacing. If you produce taller product, you can specify 4 shelves at 5 inch spacing

The RM-5T is constructed of stainless steel. The slam cam handle and cool to the touch dual pane door provide safe and easy usage. A pass-thru option is available, and allows back of the house loading, with front of the house unloading. With a small footprint, just 30" wide, and the ability to be stacked, it is the perfect convection oven to add where space may be limited.

**RM-5T Convection Oven**

**STANDARD FEATURES:**

- V-Air® technology
- Stainless steel construction
- Stainless steel legs (6")
- Cool to touch, dual pane, full view tempered glass door
- Field reversible doors
- Silicone rubber gasket on door
- Slam Cam handle
- Steam vent
- Tool-less cleaning of door glass

**OPTIONS:**

- Internal Steam
- Pass Thru
- Cook'n Hold
- Product probe
- Two Speed Fan
- Cart with Panslides (98-0350-PS)
- Cart without Panslides (98-0350-NP)
- Stand with Panslides (98-0351-PS)
- Stand without Panslides (98-0351-NP)
- Stacking Kit

**CONSTRUCTION:**

- Welded stainless steel
- Fully insulated
- Control panel accessible through front and side of unit
- Heating elements accessible inside of cabinet and through side

**CONTROLS:**

- Solid state controls
- Indicator light for thermostat
- Microswitch fan motor cut-off

**Toaster RM-5T Tabletop Convection Oven**

# RM-5T Tabletop Convection Oven

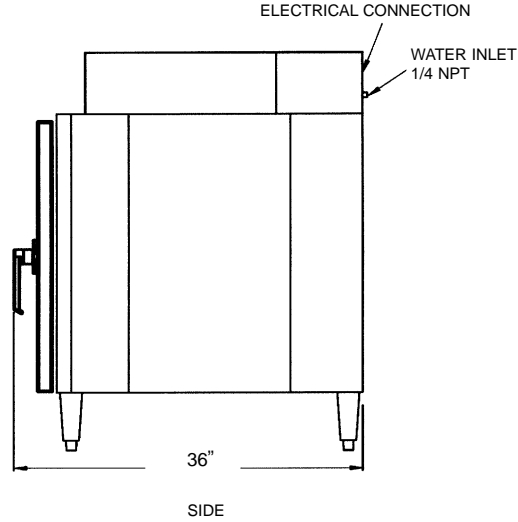
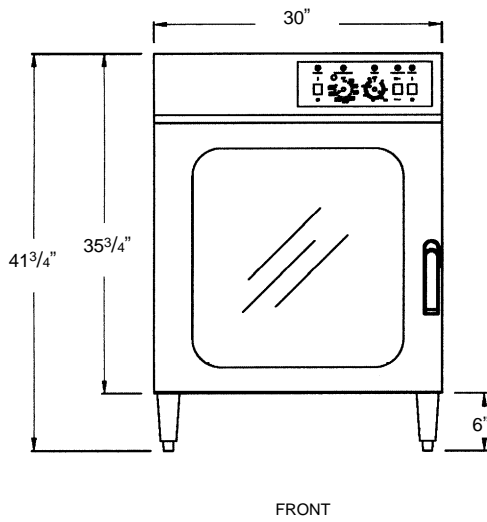

**SPECIFICATIONS:**

**ELECTRICAL:**

208 or 240 Volt single or three phase is standard. (Specify at time of order.)

**SERVICE CONNECTIONS:**

- Unit is shipped from factory to be hard wired on site. Single phase uses three wire system. Three phase uses four wire system.

**ELECTRICAL:**

Amp Draw	208/1	208/3	240/1	240/3
L1	37	30	32	26



**WATER:**

A 1/4" waterline is required if a steam option is selected. A water conditioning system should be used to minimize mineral build-up.

**INSTALLATION:**

Allow four inches on each side and back of unit for ventilation of oven.

**CAPACITY:**

	18"x26" Sheet Pans	13"x18" Sheet Pans	Spacing
Oven	5	10	4"

**DIMENSIONS:**

	Height	Width	Depth
Exterior	41-3/4"	30"	36"
Interior	22"	18-3/4"	29-3/4"

**DOOR SWING:** Oven - 30-1/2" (775 mm)

**PACKING SIZE:**

48" High, 34" Wide, 40" Deep  
(1219 mm High, 864 mm Wide, 1016 mm Deep)

**SHIPPING WEIGHT:**

400 Pounds (159 Kg), FOB Menominee, MI 49858

**INTENDED FOR COMMERCIAL USE ONLY. NOT FOR HOUSEHOLD USE.**



Toastmaster, in line with its policy to continually improve its product, reserves the right to change materials or specifications without notice. Such revisions do not entitle the buyer to corresponding changes, improvements, additions, or replacements for previously purchased equipment.

