



E9451-HP12CDNF Non-Insulated Half Height Heater / Proofer



SIZE:

E9451-HP12CDNF -

30-5/16" High, 22-13/16" Wide, 33-5/16" Deep
770 mm High, 580 mm Wide, 847 mm Deep

Toastmaster's 9451-HP12CDNF - In locations where cabinets will be used primarily for holding with infrequent serving applications (gauged by door openings) or in situations with limited start-up budgets, the non-insulated cabinet would satisfy most requirements. In higher volume operations with more frequent serving applications the insulated cabinet would be the better choice as it delivers a faster recovery and greater consistency of temperature.

CONSTRUCTION:

- Aluminum construction
- Removable heating console
- Heating elements accessible inside removable heating console

CONTROLS:

- Mechanical controls
- Indicator light for thermostat
- Separate heat and humidity controls

STANDARD FEATURES:

- Air baffle and circulation air blower provide even heat distribution
- Aluminum construction
- Set of 5" swivel casters w/brakes
- Polycarbonate door
- Magnetic door gaskets
- Lift-off door
- Full length door handle

OPTIONAL FEATURES:

- Solid door

LABORATORY CERTIFICATION AND APPROVAL



E9451-HP12CDNF Non-Insulated Half Height Heater / Proofer

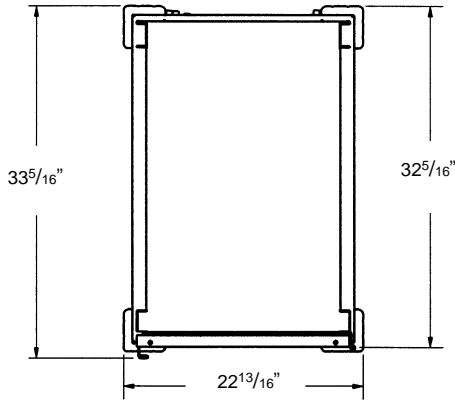

TOP

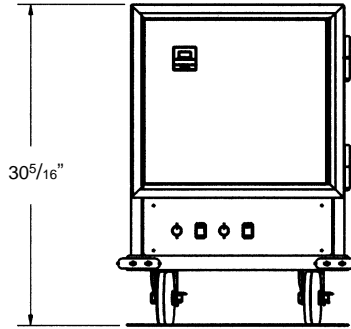

FRONT

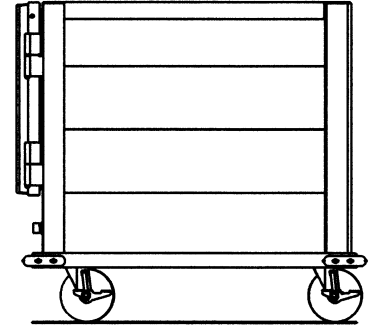

SIDE

CAPACITY:

Heater/ Proofer	18"x26" Full Size Sheet Pans	18"x26" Half Size Sheet Pans	Spacing
		11	

SPECIFICATIONS:

SERVICE CONNECTIONS:

- Unit provided with 6 foot detachable cord and plug.
- NEMA 5-20P
- Removable console consisting of blower, three-way toggle switch, running lights to indicate heater (holding) or proofing mode, stainless steel water reservoir.
- Element controlled by 180 degrees thermostat. 1500 Watts in heating mode. 1500 Watts in proofing mode.

ELECTRICAL:

Amp Draw	120/1	208/3	240/1	240/3
	14	n/a	n/a	n/a

LISTINGS:

The E9451-HP12CDNF has C-ETL-US and NSF listings.



DIMENSIONS:

	Height	Width	Depth
Exterior	30-5/16"	22-13/16"	33-5/16"
Interior	15-5/8"	18-1/8"	27-1/2"

DOOR SWING:

- Door swings 270 degrees to the recessed side of the cabinet

PACKING SIZE:

40" High, 28" Wide, 40" Deep
(1016 mm High, 711 mm Wide, 1016 mm Deep)

SHIPPING WEIGHT:

100 Pounds, FOB Menominee, MI 49858

INTENDED FOR COMMERCIAL USE ONLY. NOT FOR HOUSEHOLD USE.



Toastmaster, in line with its policy to continually improve its product, reserves the right to change materials or specifications without notice. Such revisions do not entitle the buyer to corresponding changes, improvements, additions, or replacements for previously purchased equipment.

