



Foodservice Equipment

Job _____ Item# _____

E6UAC-INS-20

Aluminum Insulated Half Height Heater / Proofer



SIZE:

E6UAC-INS-20

32-1/8" High, 27-5/8" Wide, 31-5/8" Deep

816 mm High, 702 mm Wide, 804 mm Deep

ToasterMasters's E6UAC-INS-20 - In locations where cabinets will be used primarily for holding with infrequent serving applications (gauged by door openings) or in situations with limited start-up budgets, the non-insulated cabinet would satisfy most requirements. In higher volume operations with more frequent serving applications the insulated cabinet would be the better choice as it delivers a faster recovery and greater consistency of temperature.

CONSTRUCTION:

- Aluminum construction
- Removable heating console
- Removable universal panslides

CONTROLS:

- Mechanical controls

E6UAC-INS-20 Heater/Proofer Aluminum Insulated Half Size

STANDARD FEATURES:

- Air baffle and circulation air blower provide even heat distribution
- Aluminum construction
- Insulated
- Set of 3" swivel casters w/brakes
- Polycarbonate door
- Lift-off door

OPTIONS:

- Push Handle
- Solid Door (Order as E6UAC-INS-SD-20)

LABORATORY CERTIFICATION AND APPROVAL



E6UAC-INS-20 Aluminum Insulated Half Height Heater / Proofer

E6UAC-INS-20 Aluminum Insulated Half Height Heater / Proofer

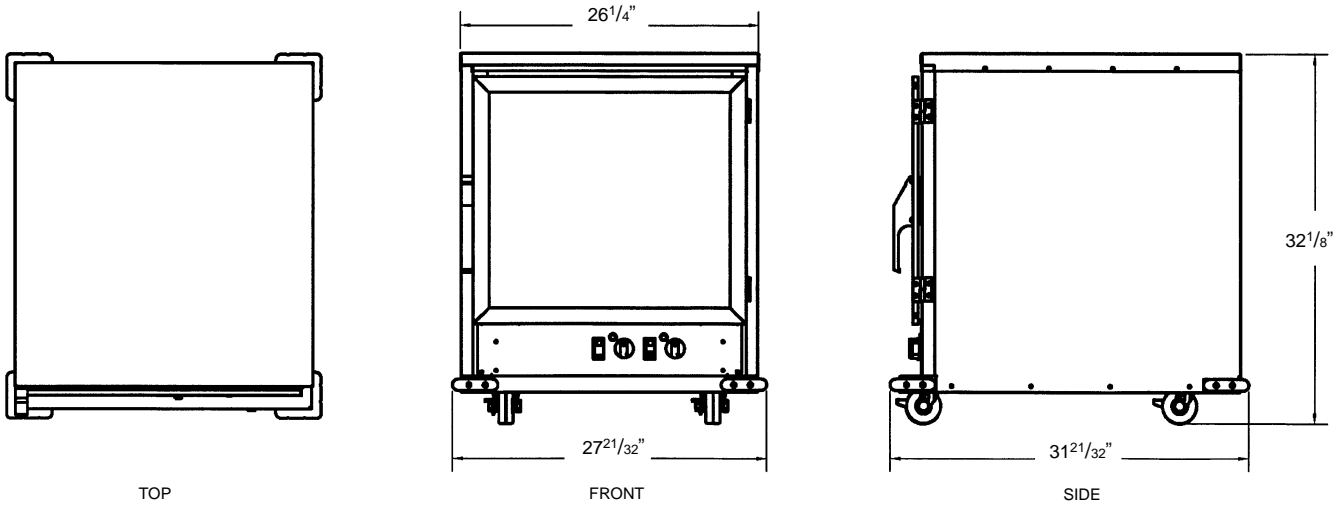

SERVICE CONNECTIONS:

- Unit provided with 6 foot detachable cord and plug
- Removable console consisting of blower, two-way toggle switch, running lights to indicate heater (holding) or proofing mode, stainless steel water reservoir.
- Element controlled by 180 degree F thermostat. 1500 Watts in heating mode. 1500 Watts in proofing mode.

ELECTRICAL:

Amp Draw	120/1	208/3	240/1	240/3
	14	n/a	n/a	n/a

- Also available in 15 amps.
Model # E6UAC-INS-15
12.5 amps - NEMA 5-15P

LISTINGS:

The E6UAC-INS-20 has C-ETL-US and NSF listings.



CAPACITY:

	18"x26" Full Size Sheet Pans	12"x20"x2-1/2" Food Service Pans	13"x18" Half Size Sheet Pans
Proofer	6	12	12
Spacing	3"	3"	3"

DIMENSIONS:

	Height	Width	Depth
Exterior	32-1/8"	27-5/8"	31-5/8"
Interior	19-1/2"	21-3/8"	27"

DOOR SWING:

- Door swings 180 degrees to the recessed side of the cabinet

PACKING SIZE:

40" High, 28" Wide, 40" Deep
(1016 mm High, 711 mm Wide, 1016 mm Deep)

SHIPPING WEIGHT:

100 Pounds, FOB Menominee, MI 49858

INTENDED FOR COMMERCIAL USE ONLY. NOT FOR HOUSEHOLD USE.



Toastmaster, in line with its policy to continually improve its product, reserves the right to change materials or specifications without notice. Such revisions do not entitle the buyer to corresponding changes, improvements, additions, or replacements for previously purchased equipment.



Toastmaster® 5600 13th Street, Menominee, MI 49858 • www.toastmastercorp.com

Toll Free: 1-800-338-9886 • Telephone: 1-906-863-4401 • Fax: 1-906-863-5889